

SPECIFICATION

MECHANICAL:

1. Housing Material: Polycarbonate, UL 94V-2, NO Poison UL 94V-0, NO Poison
2. Material Contact: Brass / Phosphor Bronze.
3. Gold Plating: FU" 2-3U" 3U" 6U" 15U" 30U" 50U"
4. Housing Color: Transparency.
5. Material Shell : Brass.
6. Operation Temperature: -40° c to 80° c.
7. Sheet copper thickness: 0.3mm
8. NO: P8-050-20/1-030-D

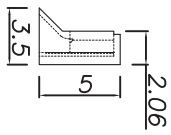
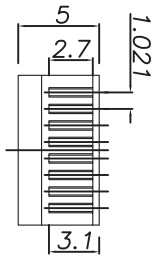
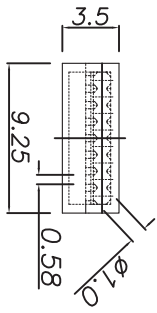

Insert

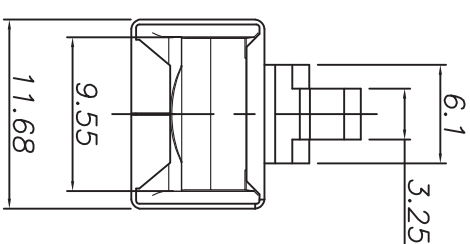
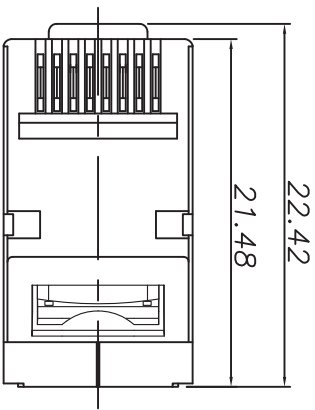
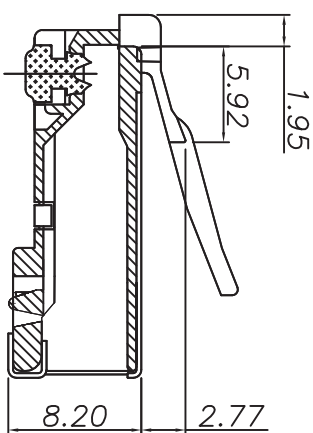
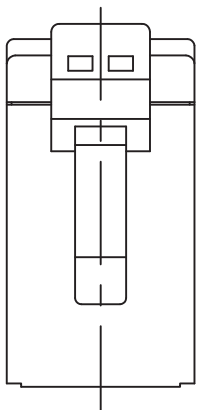
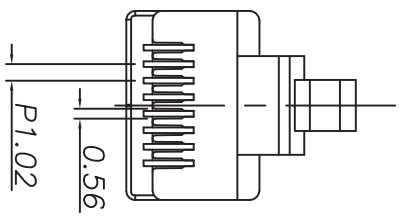
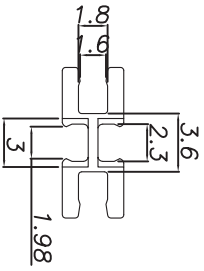
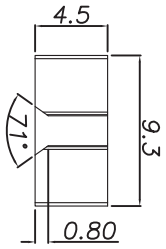

NOTE TOL: ±0.1

版本 A
 3RD 3RD
 單位 m/m
 比例 1/1